

Secondary Pit Display

(RLVBPITDSP-V2)

The Secondary Pit Display is designed to seamlessly integrate with the VBOX Pit Lane Timer, providing an exact replication of the stationary countdown time. This is particularly useful within endurance racing where the pit crew's responsibility is to safely release the car.

It can be mounted to the dash or side window, facing towards the pit crew and provides real-time information on the remaining time in the pit lane.

Housed in a splash proof case, the Pit Display connects to the coms port on the VBOX Pit Lane Timer via an attached 3.5 m flying lead. It includes in-built CAN termination.



Display Modes

OLED Pit Display has an internal accelerometer that flips the screen in accordance with the way it is mounted and can invert screen colours or display the font as a high contrast outline to match lighting conditions.

Invert screen Colour

0'03.5

0'03.5

Outline Font

0'03.5

0'03.5

Features

- Helps to avoid pit stop penalties.
- Minimises the time spent in the pits.
- Prompts pit crew when to instruct driver to leave your pit box.
- Easy operation: three buttons to scroll display screens and enter menus.
- Motorsport Standard Lemo connectors
- Low power consumption: <2W
- Multiple Mounting methods including via standard 1/4-20 UNC.
- Free lifetime customer support

Secondary Pit Display (RLVBPIDSP-V2)

Specification

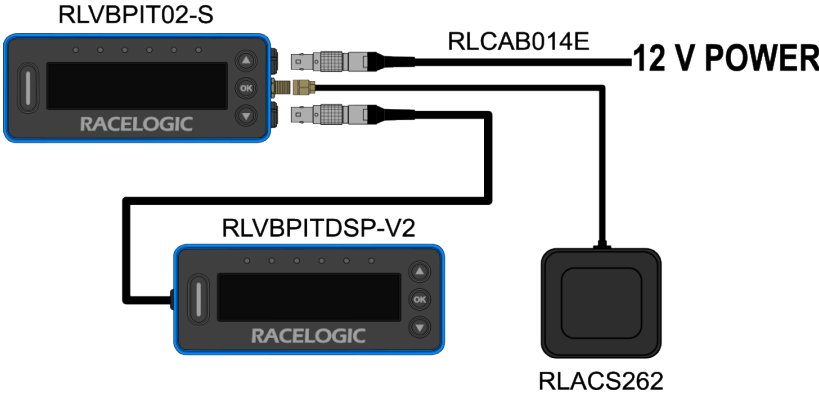
<p>Compatibility and unit connection</p>	<p>Designed to connect to VBOX Pit Lane Timer running firmware version 1.1.22 or later.</p> <p>Connect OLED Pit Display (RLVBPIDSP) to the coms port on the Pit Lane Timer using the 3.5 m flying lead.</p>	 <p>RLVBPIT02-S</p> <p>RLCAB014E</p> <p>12 V POWER</p> <p>RLVBPITDSP-V2</p> <p>RLACS262</p>
<p>IP Rating</p>	<p>IP64</p>	
<p>Operating Temp</p>	<p>-40 to +70 °C</p>	
<p>Power</p>	<p><2W</p>	
<p>Input Voltage</p>	<p>6-30 V DC</p>	
<p>Dimensions</p>	<p>120 x 50 x 19.5 mm (excluding cable)</p>	
<p>Weight</p>	<p>204 g (including attached cable)</p>	

Package Contents

RLVBPIDSP-V2	Product Code
OLED Pit Display with 3.5 m flying lead and suction mount	RLVBDSP07-L